

SONANCE

PATIO SERIES DATA SHEET

(4) SATELLITES | (4) GROUND STAKES | (1) SUBWOOFER
 OPTIONAL: (1) 2-100 AMPLIFIER

TECHNICAL SPECIFICATIONS

| Model | Satellite | Subwoofer |
|----------------------------|----------------------------------------------------------------------|----------------------------------------------------------------------|
| Driver | 3.5" (98mm) Anodized aluminum cone and Santoprene™ surround | 8" (203mm) dual voice coil, polypropylene and Santoprene surround |
| Frequency Response | 40Hz - 20kHz +/-3dB (System) | 40Hz - 20kHz +/-3dB (System) |
| Crossover Frequency | 125Hz | 100Hz |
| Impedence | 16 Ohms nominal | 8 Ohms nominal per voice coil |
| System Impedence | 8 Ohms nominal | 8 Ohms nominal |
| Power Handling | 50 watts minimum; 150 watts maximum | 150 Watts |
| Sensitivity | 85dB 2.83V / 1 meter | 89dB Sensitivity @ 2.83V / 1 meter |
| Enclosure Material | High-heat ABS sealed enclosure, Non-corroding | High-heat ABS sealed enclosure, Non-corroding |
| Mounting Threads | 1/2" NPS (National Pipe Standard) | - |
| Product Dimensions (WxHxD) | 6.75" x 4.5" (171.35mm x 115mm) | 21.4" x 12.4" (544mm x 315mm) |
| Shipping Weight | 41.7 lbs (19 kg) System, no Amp 52.8 lbs (24 kg) System, with Amp | 41.7 lbs (19 kg) System, no Amp 52.8 lbs (24 kg) System, with Amp |

DIMENSIONAL DRAWINGS

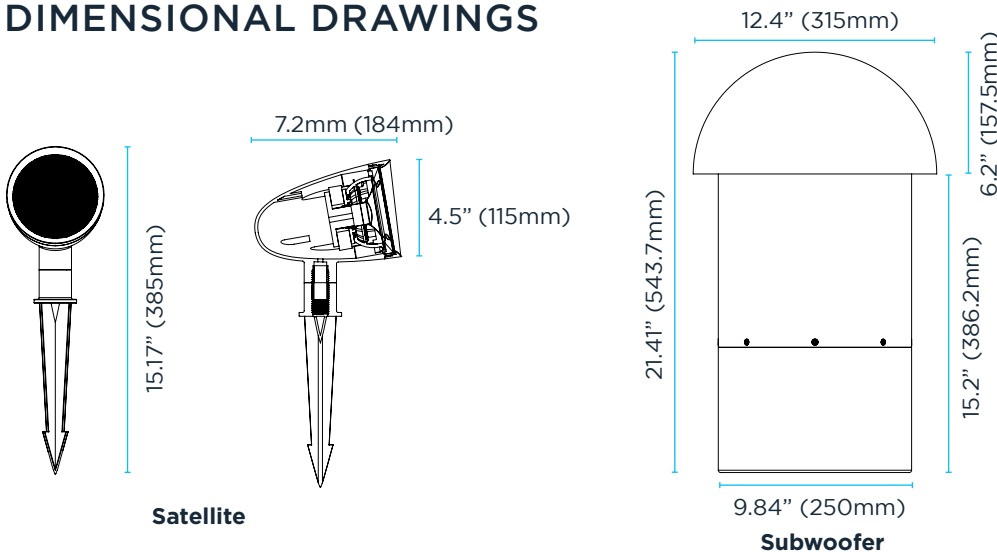

Patio Series 4.1 System
2-100 Amplifier
 SKU 93553

Patio Series 4.1 System
(no amp)
 SKU 93429